

### Features

1. Molded epoxy body.
2. Zero crossing circuit.
3. High input/output insulation.
4. Small size and light weight.
5. Can be installed directly on the PC board.
6. Fast reactive speed.
7. Normally open.

### Applications

1. Household Appliances.
2. Temperature Control System.
3. Industrial Automatic Control.
4. Lighting System.
5. Office Appliances.
6. Factory Appliances.

### Outside Dimension : Unit (mm)

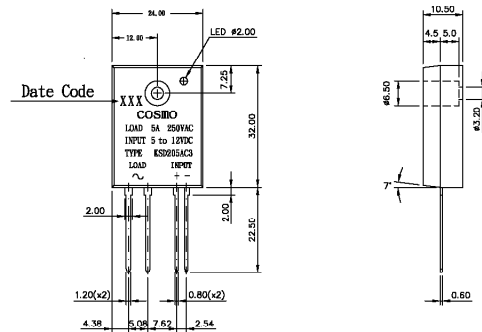

### Schematic : Top View

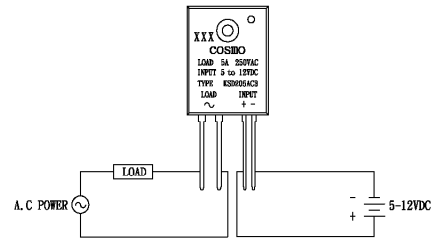

### Absolute Maximum Ratings

(Ta=25°C)

Parameter		Symbol	Rating	Unit
Input	Input Signal Voltage	V <sub>IN</sub>	5~12	VDC
	Drop-out Voltage	V <sub>DO</sub>	1	VDC
Output	RMS on-state current	I <sub>T</sub>	5	Arms
	Peak one cycle surge current (8.3 ms)	I <sub>surge</sub>	50	A
	Repetitive peak-off state Voltage	V <sub>DRM</sub>	600	V
	Operating frequency	f	47~70	Hz
	Critical rate of rise of on-state current	di/dt	50	A/μS
	Load supply voltage	V <sub>out</sub>	250	Vrms AC
	Isolation Voltage input to output	V <sub>iso</sub>	4000	Vrms
Operating Temperature		T <sub>opr</sub>	-30~100	°C
Storage Temperature		T <sub>stg</sub>	-30~125	°C
Soldering Temperature 10 Sec		T <sub>sol</sub>	260	°C

### Electrical Characteristics

(Ta=25°C)

Parameter		Symbol	Conditions	MIN	TYP	MAX	Unit
Input	Pick-up Voltage	V <sub>pu</sub>	I <sub>T</sub> =1Arms			4	VDC
	Input current	I <sub>in</sub>	V <sub>in</sub> =5-12V	5		35	mA
Output	On-state Voltage	V <sub>T</sub>	I <sub>T</sub> =1Arms			1.5	Vrms
	Operating Current	I <sub>op</sub>	V <sub>out</sub> =240Vrms	50			mArms
	Leakage Current	I <sub>leak</sub>	V <sub>out</sub> =240Vrms			7	mArms
	Critical rate of rise of off-state Voltage	dv/dt	See Note 1	50	200		V/μS
	Zero-cross Voltage				Yes		
	Load Voltage Rating	V <sub>out</sub>	I <sub>T</sub> =50mArms MIN	50		280	VAC
Minimum trigger current		I <sub>FT</sub>	V <sub>DRM</sub> =600V			10	mA
Isolation resistance input to output		R <sub>iso</sub>	DC500V	10 <sup>10</sup>			Ω
Turn-on time		T <sub>on</sub>	60Hz AC			8.3	mS
Turn-off time		T <sub>off</sub>	60Hz AC			8.3	mS
Thermal resistance (between junction and case)		R <sub>th(j-c)</sub>			1.3		°C/W

Note1 : Output (dv/dt) protection is provided in all models, and they are designed to switch resistive or inductive loads to 0.2 power factor. The dv/dt rating is based on source impedance of 50 ohms.

## Data Curve

